

**1995 Auto Car Tandem / Tandem Flushby
Diesel**



Serial Number 4V2SMBJH2SR514540

#14A 1995 Auto Car Flushby

Inspection June 16, 2017

24,000 hours - inspection covers

- 142	- 2017 hours operated
- 536	- 2018
- 471	- 2019

22,851 hours remaining on inspection cert.



Kodiak Engineering Ltd.

Suite 101A, 957 Fir Street, Sherwood Park, AB T8A 4N6 • Office: (780) 416-2125 • Fax: (780) 416-2780 • Cell: (780) 910-3533 • Email: fyzyk@kodiakeng.com

June 16, 2017

Southern Pressure Tester's Ltd.
Box 26
Gull Lake, Saskatchewan
S0N 1A0

RE: LEVEL IV CERTIFICATION OF FLUSHBY MAST AND BASE

Model:	Lash Enterprises Ltd. Flushby Mast
Serial Number:	01-80149 (Modified)
Mast Height:	53.5 ft / 16.3 m
Maximum Hook:	50,000 lbs. / 22,240 daN / 2 lines
Maximum Wind:	69 mph / 111 kph
Owner:	Southern Pressure Tester's Ltd. – Rig #12 X 14A
Our File:	17-06-9697/0

The above rig was cleaned for Level IV inspection and certification. We performed visual and magnetic particle inspections as per the attached inspection summary. All defects were identified for repair. The repairs were completed by Southern Pressure Tester's at their Gull Lake, Saskatchewan facility. AM Inspection Ltd. of Cabri, Saskatchewan performed a visual and magnetic particle inspection of the completed repairs as per report number JC 42900 1. No indications were noted at time of the final inspection.

Based on the inspections performed and the repairs completed, it is our opinion that the mast and base are safe operating structures and may be placed into service within the above ratings and specifications as determined by Allan R. Nelson Engineering (1997) Inc. File Number 03-03-13939.

This certification covers the above described mast and base for 24,000 operating hours, with inspections by a qualified person as per CAODC Recommended Practice R.P. 3.0, or until the mast and base are damaged by either handling, transportation or operation.

PERMIT TO PRACTICE KODIAK ENGINEERING LTD.	
Signature	<i>[Signature]</i>
Date	June 16, 2017
PERMIT NUMBER: P 7518	
The Association of Professional Engineers, Geologists and Geophysicists of Alberta	





Kodiak Engineering Ltd.

Suite 101A, 957 Fir Street, Sherwood Park, AB T8A 4N6 • Office: (780) 416-2125 • Fax: (780) 416-2780 • Cell: (780) 910-3533 • Email: fyzyk@kodiakeng.com

June 16, 2017

Southern Pressure Tester's Ltd.
Box 26
Gull Lake, Saskatchewan
S0N 1A0

RE: LEVEL IV CERTIFICATION OF LASH ENTERPRISES CROWN
Mast Model: Lash Enterprises Ltd. Flushby Mast
Mast Serial Number: 01-80149 (Modified)
Drill Line Sheaves: 2 x 18" x 7/8" Groove
Owner: Southern Pressure Tester's Ltd. – Rig #12 ~~12~~ 14A
Our File: 17-06-9697/1

The above crown was disassembled and cleaned for Level IV inspection and certification. We performed visual and magnetic particle inspections as per the attached inspection summary. No relevant indications were noted at time of inspection. The crown was assembled by Southern Pressure Tester's Ltd. at their Gull Lake, Saskatchewan facility.

Based on the inspections performed, it is our opinion that the crown is a safe operating structure and may be placed into service within the above ratings and specifications as per Allan R. Nelson Engineering (1997) Inc. File Number 03-03-13939.

This certification covers the above described crown for 24,000 operating hours, with inspections by a qualified person as per CAODC Recommended Practice R.P. 3.0, or until the crown is damaged by either handling, transportation or operation.

PERMIT TO PRACTICE KODIAK ENGINEERING LTD.	
Signature	<i>F. Colucci</i>
Date	<i>June 16, 2017</i>
PERMIT NUMBER: P 7518	
The Association of Professional Engineers, Geologists and Geophysicists of Alberta	





Kodiak Engineering Ltd.

Suite 101A, 957 Fir Street, Sherwood Park, AB T8A 4N6 • Office: (780) 416-2125 • Fax: (780) 416-2780 • Cell: (780) 910-3533 • Email: fyzyk@kodiakeng.com

June 16, 2017

Southern Pressure Tester's Ltd.
Box 26
Gull Lake, Saskatchewan
S0N 1A0

RE: CERTIFICATION OF CLIMBING LINE ANCHOR
Mast Model: Lash Enterprises Ltd. Flushby Mast
Mast Serial Number: 01-80149 (Modified)
Anchorage Capacity: 5,000 lbs / 2,224 daN
Owner: Southern Pressure Tester's Ltd. - Rig #12 *14A*
Our File: 17-06-9697/2

The climbing line anchor at the crown has been designed to support the retractable climbing line at the crown. This anchor is rated for the above capacity, which is required for the climbing line anchor point as outlined by the climbing line OEM.

Based on our inspection of the climbing line anchor, it is our opinion that the climbing line anchor is a safe operating structure and may be placed into service within the above ratings and specifications.

This certification covers the above described climbing line anchor for 24,000 operating hours, with inspections by a qualified person as per CAODC Recommended Practice R.P. 3.0, or until the climbing line anchor is damaged by either handling, transportation or operation.

**PERMIT TO PRACTICE
KODIAK ENGINEERING LTD.**

Signature *F. Colucci*

Date June 16, 2017

PERMIT NUMBER: P 7518

The Association of Professional Engineers,
Geologists and Geophysicists of Alberta

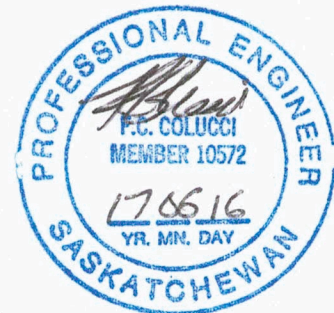

Flush-By Inspection Report

File No:	17-06-9697
Date:	June 16, 2017
Rig:	Southern Pressure Tester's Ltd. - Rig #12 14A

	Visual	MPI	Comments
Crown Assembly			
Structure - Beams, Pedestals	Y	Y	See report K-09691.
Sheaves	Y	Y	See report K-09690.
Grooves	Y		
Side Play			Sheaves were disassembled at time of inspection.
Line Guards	Y	Y	
Mast Structure			
Main Derrick Legs	Y	Y	See reports K-09691 and JC 42900 1.
Cross Members / Girts	Y	Y	
Locking Assembly	n/a		
Scoping Assembly	n/a		
Hinge Lugs	Y	Y	See report K-09691.
Hinge Pins	Y	Y	See report K-09691.
Adjusting Nuts / Screws	n/a		
Rod Basket			
Frame Structure			Not equipped with a rod board.
Fingers			
Lugs / Pins			
Basket			
Mast Base			
Hinge Lugs	Y	Y	See report K-09692.
A-leg Structure	Y	Y	See report K-09692.
Turnbuckles / A-legs	n/a		
Carrier Equipment			
Rear Bumper	Y	Y	See report K-09692.
Deadline Anchor	Y	Y	See report K-09691.
Raising Cylinder Lugs / Pins	Y	Y	See reports K-09692 & K-09691.
Headache Rack	Y	Y	See report K-09692.
Stiff Legs (Slant)	n/a		
Load Line Anchors	Y	Y	See report K-09692.
Leveling Jacks	Y	Y	See report K-09692.

Plaque Information:

Model:	Lash Enterprises Ltd. - Flushby Mast
S/N:	01-80149 (Modified)
Hook:	50,000 lbs / 22,240 daN / 2 Lines
Wind:	69 mph / 111 kph

Comments:

1. Rig disassembled and cleaned for Level IV inspection and certification.
2. All repairs were completed by Southern Pressure Tester's Ltd. at their Gull Lake, Saskatchewan facility.
3. Inspections performed by Kodiak Engineering Ltd. and AM Inspections Ltd. of Cabri, Saskatchewan.

CLIENT: Southern Pressure Tester's Ltd. PAGE: 1 OF 3
 LOCATION: HA Southern Pressure Tester's shop - Gull Lake, Saskatchewan DATE: June 13, 2017
 ITEM TESTED: Rig #12 - Inspect crown sheaves and shafts. JOB No.: 17-06-9697

EQUIPMENT: Parker B310 S/N: 2336 PARTICLES: Ancolor Yellow
 AC DC YOKE COIL CONTINUOUS DRY WET
 COLOR CONTRAST: _____ FLUORESCENT: _____ BLACK LIGHT: _____
 KODIAK CODE: MT-03 ACCEPTANCE: _____
 BARE METAL SANDBLASTED PAINTED MACHINED AS CLEANED

EXAMINATION:

100% visual and magnetic particle inspection was performed on the crown sheaves (18" Dia. x2) and shafts for Southern Pressure Tester's Ltd. Rig #12.

RESULTS:

No relevant indications were noted at time of inspection.

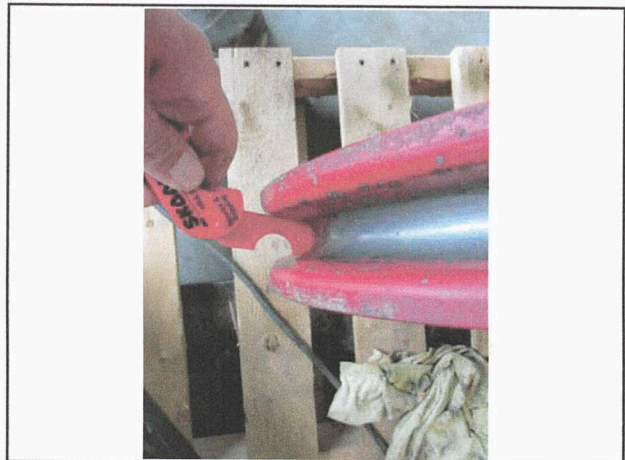
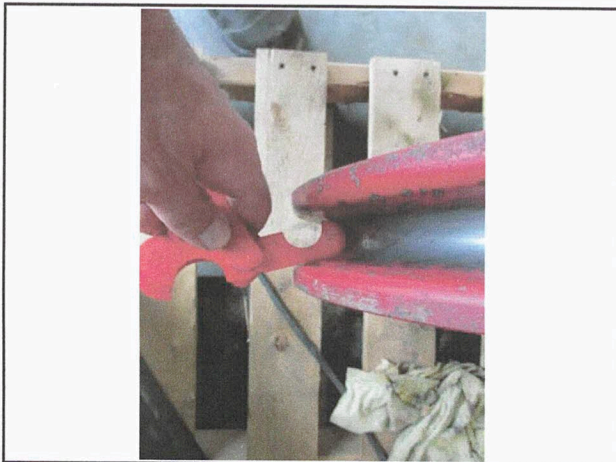

TECHNICIAN (PRINT): Francis Colucci, P.Eng. (SIGN): *Francis Colucci* CGSB #: _____

CLIENT: Southern Pressure Tester's Ltd.

PAGE: 2 OF 3

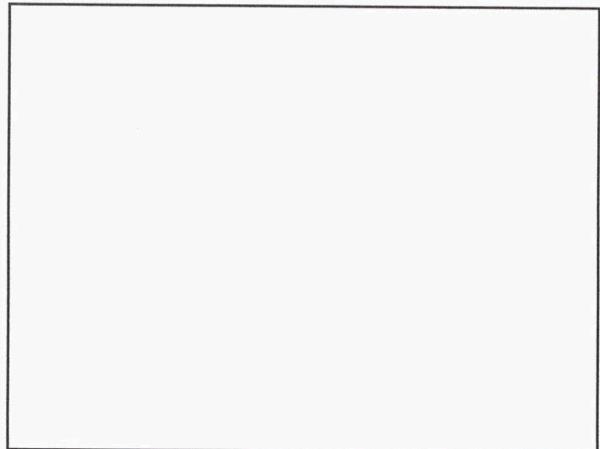
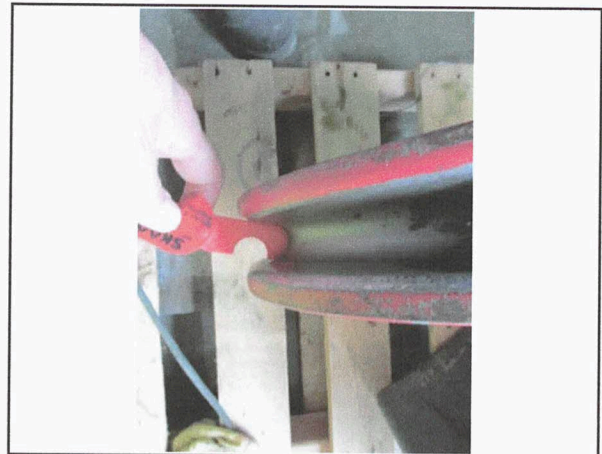
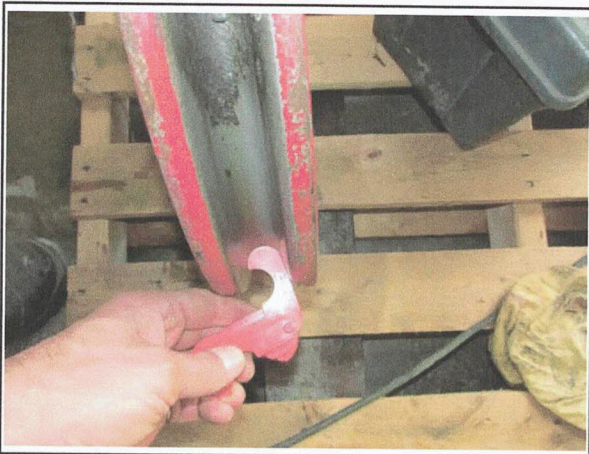

CLIENT: Southern Pressure Tester's Ltd.

PAGE: 3 OF 3

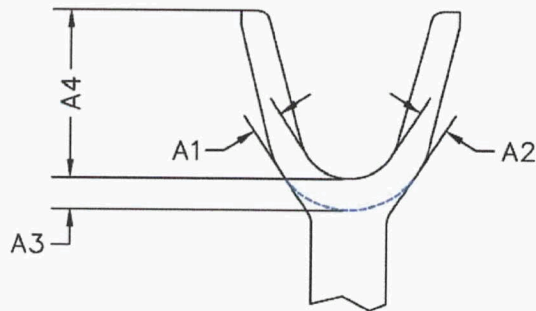
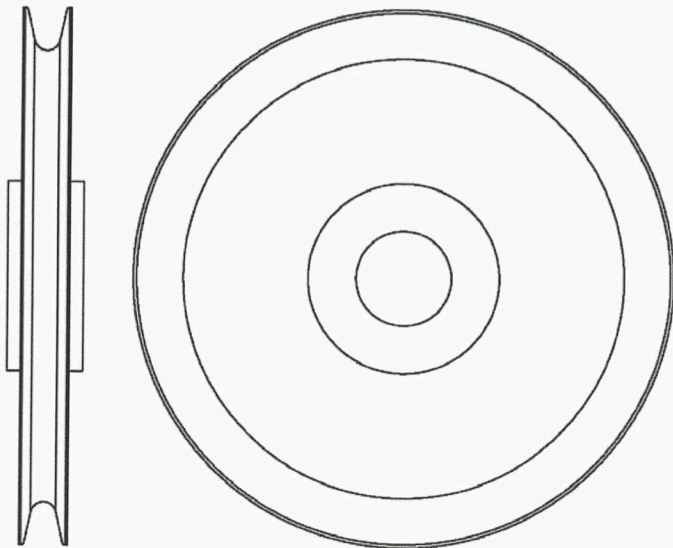

DESCRIPTION: 18" Dia. x 7/8" Groove

STAMPED: _____

STEEL NYLATRON

A1 - WALL THICKNESS: _____

A2 - WALL THICKNESS: _____

A3 - TREAD THICKNESS: _____

A4 - GROOVE DEPTH: 1.203"

GROOVE CABLE SIZE: 7/8"

GROOVE GAUGE: GOOD NG

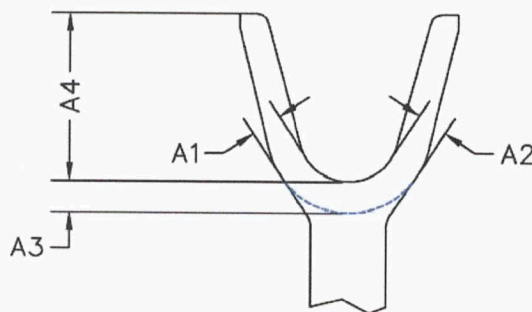
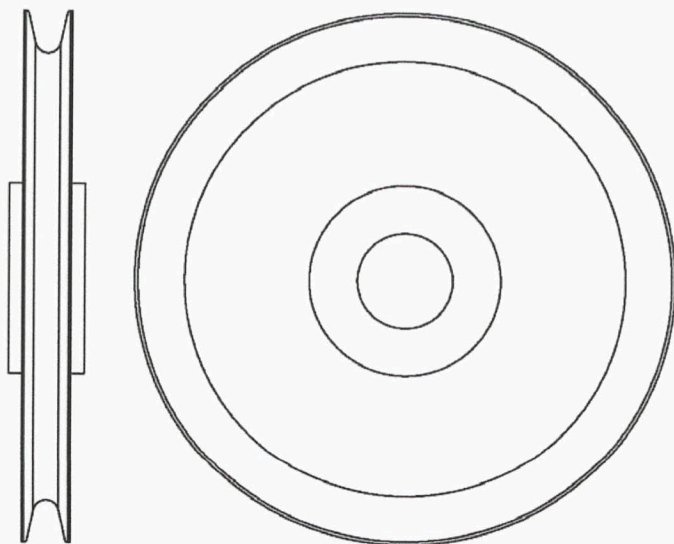

DESCRIPTION: 18" Dia. x 7/8" Groove

STAMPED: _____

STEEL NYLATRON

A1 - WALL THICKNESS: _____

A2 - WALL THICKNESS: _____

A3 - TREAD THICKNESS: _____

A4 - GROOVE DEPTH: 1.202"

GROOVE CABLE SIZE: 7/8"

GROOVE GAUGE: GOOD NG

CLIENT: Southern Pressure Tester's Ltd. PAGE: 1 OF 3
 LOCATION: ^{14A} Southern Pressure Tester's shop - Gull Lake, Saskatchewan DATE: June 13, 2017
 ITEM TESTED: ~~Rig #12~~ - Inspect flushby mast. JOB No.: 17-06-9697

EQUIPMENT: Parker B310 S/N: 2336 PARTICLES: Ancolor Yellow
 AC DC YOKE COIL CONTINUOUS DRY WET
 COLOR CONTRAST: _____ FLUORESCENT: _____ BLACK LIGHT: _____
 KODIAK CODE: MT-03 ACCEPTANCE: _____
 BARE METAL SANDBLASTED PAINTED MACHINED AS CLEANED

EXAMINATION:

100% visual and magnetic particle inspection was performed on the flushby mast, crown pedestals, climbing line anchor, mast hinge pins and raising cylinder pins for Southern Pressure Tester's Ltd. Rig #12.

RESULTS:

Defects were identified for repair at the raising cylinder lugs on the mast.



TECHNICIAN (PRINT): Francis Colucci, P.Eng. (SIGN):  CGSB #: _____

CLIENT: Southern Pressure Tester's Ltd.

PAGE: 2 OF 3

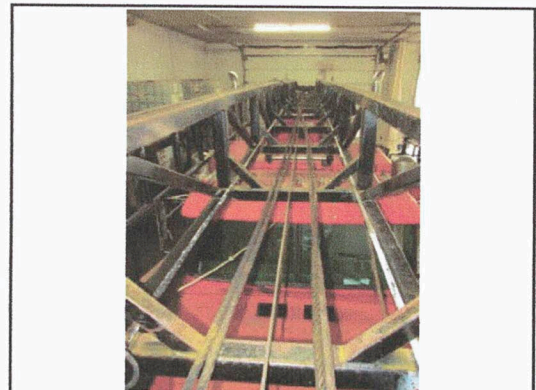
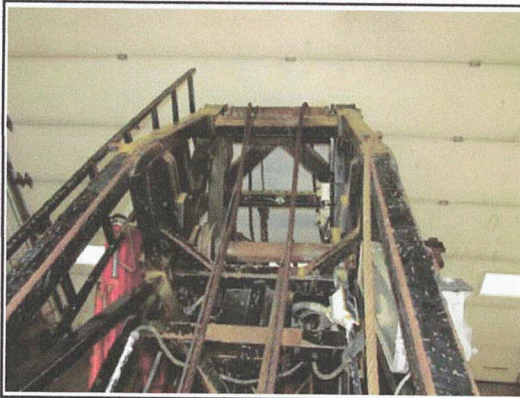

CLIENT: Southern Pressure Tester's Ltd.

PAGE: 3 OF 3

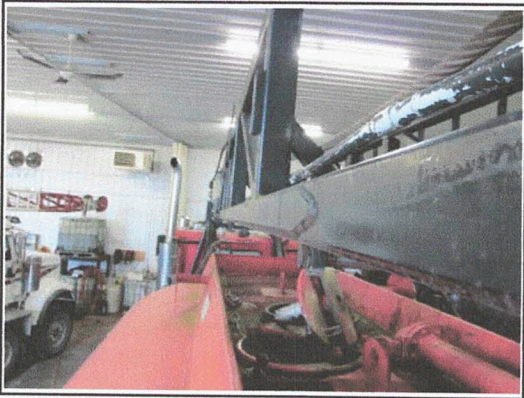
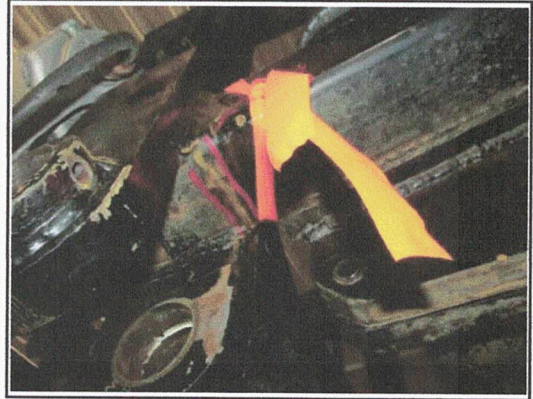
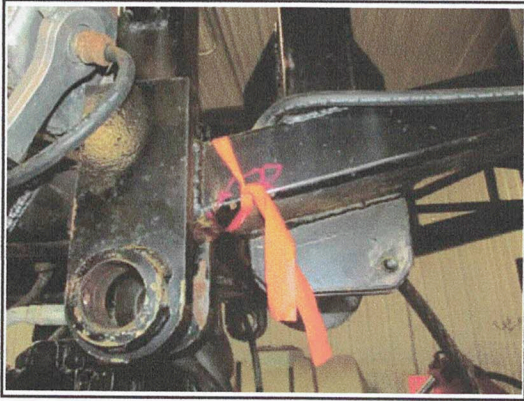

CLIENT: <u>Southern Pressure Tester's Ltd.</u>	PAGE: <u>1</u> OF <u>3</u>
LOCATION: HA <u>Southern Pressure Tester's shop - Gull Lake, Saskatchewan</u>	DATE: <u>June 13, 2017</u>
ITEM TESTED: <u>Rig #12 - Inspect flushby carrier.</u>	JOB No.: <u>17-06-9697</u>
EQUIPMENT: <u>Parker B310</u> S/N: <u>2336</u> PARTICLES: <u>Ancolor Yellow</u>	
AC <input checked="" type="checkbox"/> DC <input type="checkbox"/> YOKE <input checked="" type="checkbox"/> COIL <input type="checkbox"/> CONTINUOUS <input checked="" type="checkbox"/> DRY <input checked="" type="checkbox"/> WET <input type="checkbox"/>	
COLOR CONTRAST: _____ FLUORESCENT: _____ BLACK LIGHT: _____	
KODIAK CODE: <u>MT-03</u> ACCEPTANCE: _____	
BARE METAL <input type="checkbox"/> SANDBLASTED <input type="checkbox"/> PAINTED <input checked="" type="checkbox"/> MACHINED <input type="checkbox"/> AS CLEANED <input checked="" type="checkbox"/>	

EXAMINATION:

100% visual and magnetic particle inspection was performed on the mast base, rear bumper, raising cylinder lugs, front jacks, load line anchors and headache rack for Southern Pressure Tester's Ltd. Rig #12.

RESULTS:

No relevant indications were noted at time of inspection.

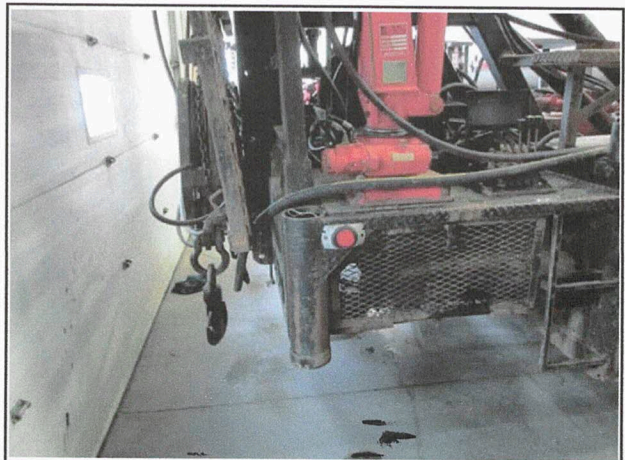

CLIENT: Southern Pressure Tester's Ltd.

PAGE: 2 OF 3

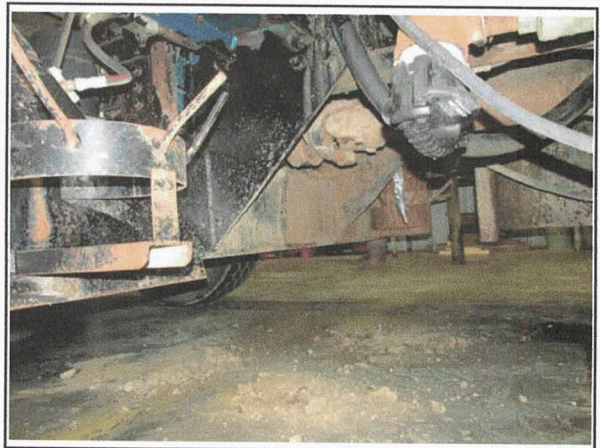
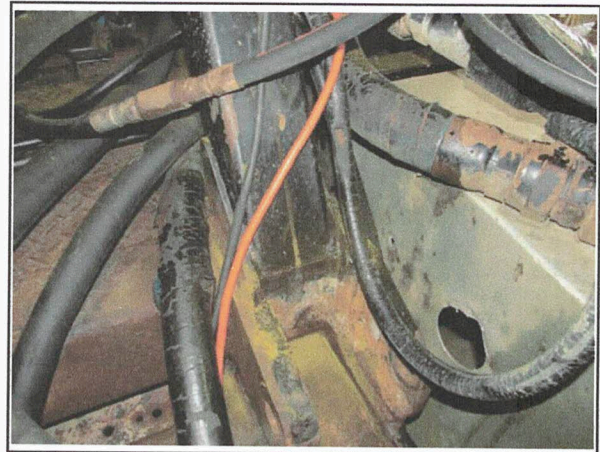
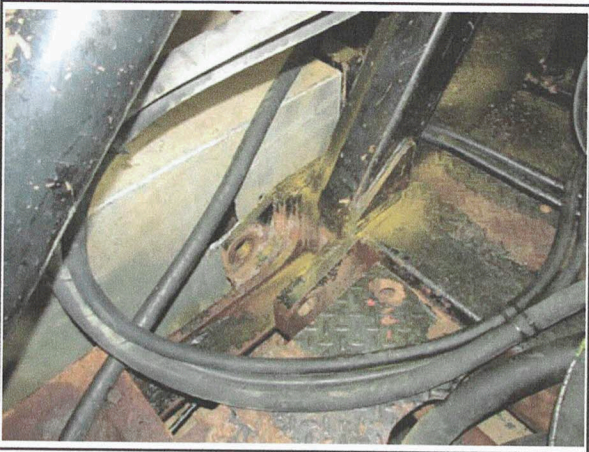
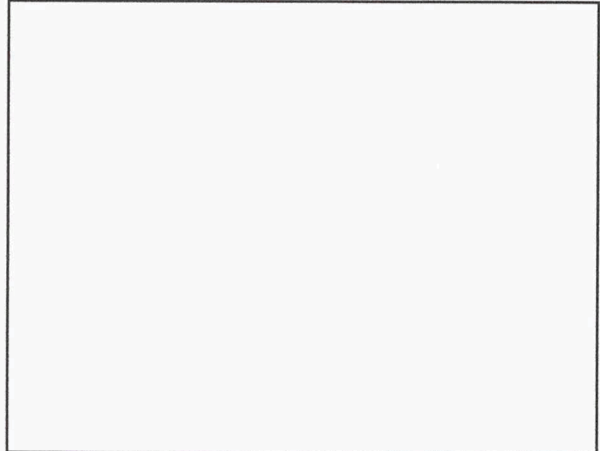

CLIENT: Southern Pressure Tester's Ltd.

PAGE: 3 OF 3

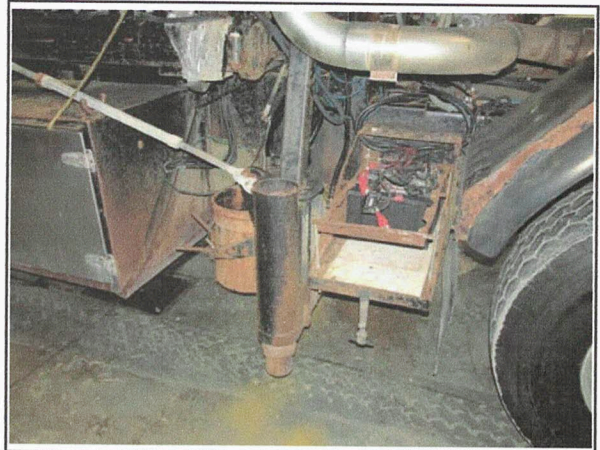
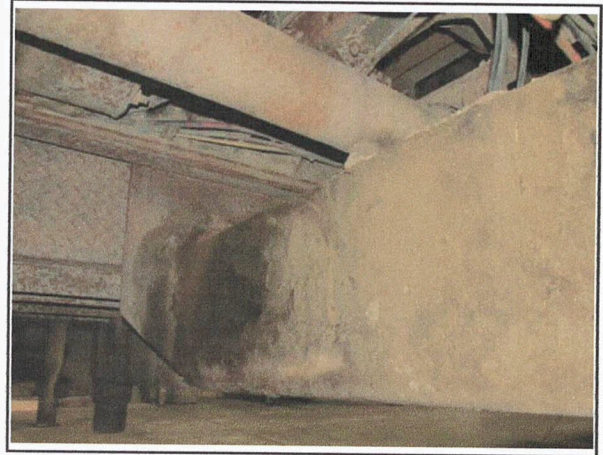
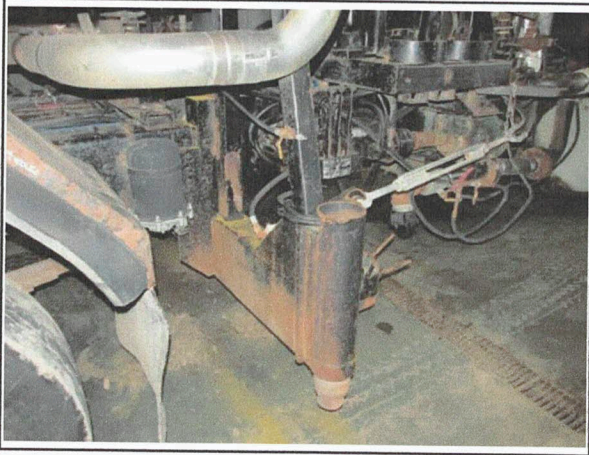



AM INSPECTION LTD.

Your Non-Destructive Testing Specialists

Date 14-Jun-17

Page 1 of 1

JC 42900 1

Box 463, Cabri, Saskatchewan S0N 0J0

Cabri Office: (306) 587-2620

Cabri Fax: (306) 587-2805

Toll Free: 1-800-667-6747

E-mail: am.inspection@sasktel.net

Website: www.aminspection.ca

MAGNETIC PARTICLE / LIQUID PENETRANT EXAMINATION REPORT

CLIENT: Southern Pressure Testers JOB #: AMI16664
 LOCATION: Gull Lake Sask JOB CALL #: _____
 ITEM(S) EXAMINED: Repairs to Autocar Flushby
 PROCEDURE #: MP1A CLIENT P.O. # / JOB #: _____
 ACCEPTANCE SPECIFICATION: Customer Specs W59

SURFACE CONDITION Clean Bare Metal As Ground Machined Shot Blast Painted Other _____
 EQUIPMENT TYPE: Yoke Coil Bench Prod Serial #: _____ Last Calibration Date: 1/6/17
 Black light Serial #: _____ Calibr.Date: _____ Calibration: _____ uw/cm²: _____

MPI METHOD: AC DC HW Rectified / Continuous Residual 120 V 12 V Other _____
 MEDIUM: Dry (Colour _____) Wet Fluorescent Black on white

LPI PRODUCT MANUFACTURER: _____
 PRODUCT TYPE: Penetrant _____ Emulsifier _____ Remover _____ Developer _____
 Penetrant: Visible Fluorescent Water Washable Post Emulsified Solvent Removable
 Developer: Wet Dry Nonaqueous

TEST RESULTS MPI repairs to Autocar Flushby

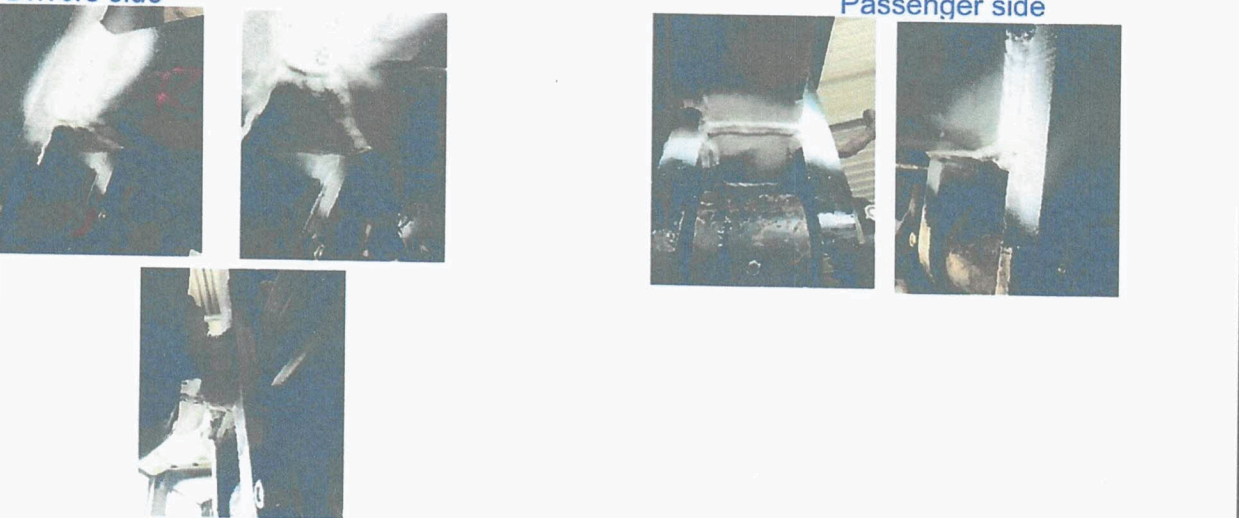

no indications at time of inspection

STAMP
JIM CARLETON
 ASNT II
 CGSB.48.9712 L II
 4064

Sub Days	KMS.	Reg.Hrs.	OT.Hr
	<u>120</u>	<u>3</u>	

Client Signature: [Signature]
 Client Print: Kevin Wickenheiser
 Technician Signature: [Signature]
 Assistant Print: _____



AM INSPECTION LTD.

Your Non-Destructive Testing Specialists

Date 14-Jun-17

Page 1 of 1

JC 42900 1

Box 463, Cabri, Saskatchewan S0N 0J0

Toll Free: 1-800-667-6747

Cabri Office: (306) 587-2620

E-mail: am.inspection@sasktel.net

Cabri Fax: (306) 587-2805

Website: www.aminspection.ca

MAGNETIC PARTICLE / LIQUID PENETRANT EXAMINATION REPORT

CLIENT: Southern Pressure Testers JOB #: AMI16664

LOCATION: Gull Lake Sask JOB CALL #: _____

ITEM(S) EXAMINED: Repairs to Autocar Flushby

PROCEDURE #: MP1A CLIENT P.O. # / JOB #: _____

ACCEPTANCE SPECIFICATION: Customer Specs W59

SURFACE CONDITION Clean Bare Metal As Ground Machined Shot Blast Painted Other _____

EQUIPMENT TYPE: Yoke Coil Bench Prod Serial #: _____ Last Calibration Date: 1/6/17

Black light Serial #: _____ Calibr.Date: _____ Calibration: _____ uw/cm²: _____

MPI METHOD: AC DC HW Rectified / Continuous Residual 120 V 12 V Other _____

MEDIUM: Dry (Colour _____) Wet Fluorescent Black on white

LPI PRODUCT MANUFACTURER: _____

PRODUCT TYPE: Penetrant _____ Emulsifier _____ Remover _____ Developer _____

Penetrant: Visible Fluorescent Water Washable Post Emulsified Solvent Removable

Developer: Wet Dry Nonaqueous

TEST RESULTS MPI repairs to Autocar Flushby

Drivers side

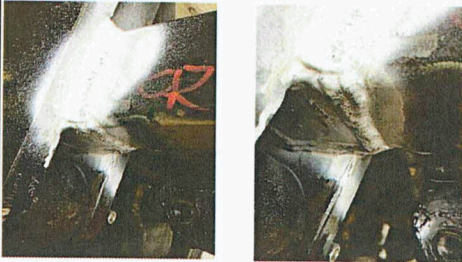

Passenger side



no indications at time
of inspection

STAMP
JIM CARLETON
ASNT II
CGSB.48.9712 L II
4964

Sub Days	KMS.	Reg.Hrs.	OT.Hr
	120	3	

Client Signature: _____

Client Print: Bob Hansen

Technician Signature:

Assistant Print: _____

Southern Pressure Testers Ltd.
Transaction Detail By Account
January 2017 through December 2022

Date	Name	Memo	Amount	Balance
Repair & Maintenance Exp - 5770				
#14A R&M				
05/31/2017	Central Energy Servi...	Central-wash flush-by for inspectio...	858.60	858.60
06/15/2017	Brake & Drive	B&D- CR seal	68.70	927.30
06/16/2017	Warner Industries S...	Warner-fuel filter	20.78	948.08
06/16/2017	Kodiak Engineering ...	Kodiak-inspection (inspection - not...	5,895.00	6,843.08
06/16/2017	Raven Oilfield Supply	Raven-paint-plugs-rags	213.15	7,056.23
06/19/2017	Skky Industrial Inc - ...	inspect tank-Skky (inspection not c...	1,500.30	8,556.53
06/20/2017	Napa / UAP Inc.	Napa-tools-paint	85.87	8,642.40
06/20/2017	Nodge Manufacturing	Nodge- fitting-fuel system	13.38	8,655.78
06/20/2017	Brake & Drive	B&D-air intake hose	143.11	8,798.89
06/21/2017	Warner Industries S...	Warner-vent plug	29.68	8,828.57
06/21/2017	Warner Industries S...	Warner-snap ring	2.88	8,831.45
06/21/2017	Brake & Drive	B&D-brake linkage	24.26	8,855.71
06/23/2017	ParaMount Hydraul...	Paramount-levelling jack (replace...	3,812.50	12,668.21
06/23/2017	Napa / UAP Inc.	Napa-paint gun	231.82	12,900.03
06/23/2017	Napa / UAP Inc.	Napa-masking tape	43.49	12,943.52
06/23/2017	Napa / UAP Inc.	Napa-sand paper	89.69	13,033.21
06/23/2017	Warner Industries S...	Warner-axle gaskets	12.44	13,045.65
06/23/2017	Warner Industries S...	Warner-battery nuts-wheel caps	96.96	13,142.61
06/27/2017	Central Energy Servi...	Central-inspect fie ex	346.73	13,489.34
06/27/2017	Napa / UAP Inc.	Napa-paint	6.67	13,496.01
06/27/2017	Napa / UAP Inc.	Napa-paint	879.04	14,375.05
06/29/2017	Brake & Drive	B&D-gear box seals	193.67	14,568.72
06/30/2017	A M Inspection Ltd	AM Inspection	603.14	15,171.86
06/30/2017	Pioneer Co-op	painting supplies-Co-op	22.91	15,194.77
06/30/2017	Pioneer Co-op	paint-Co-op	47.00	15,241.77
06/30/2017	Pioneer Co-op	rug doctor-Co-op	58.89	15,300.66
06/30/2017	Master Card	South Point-fuel hose fittings-MC	26.28	15,326.94
06/30/2017	Master Card	Applied-drop box fittings-MC (repai...	1,315.40	16,642.34
06/30/2017	Master Card	Home Depot-paint supplies-MC	15.72	16,658.06
06/30/2017	Master Card	Can Tire-reducer sand paper-plasti...	263.37	16,921.43
06/30/2017	Master Card	Sterling-belt-seal-sheild-dip stick-...	1,014.46	17,935.89
06/30/2017	Master Card	Sterling-rear diff axle lock gear-MC	695.63	18,631.52
06/30/2017	Master Card	Applied-drop box-bearing-seal-MC	483.02	19,114.54
06/30/2017	Master Card	Diamond Steel-tank bolts-MC	28.87	19,143.41
06/30/2017	Master Card	Can Tire-sanding disks-MC	55.45	19,198.86
07/01/2017	Greyhound	Greyhound-Applied Industrial	89.51	19,288.37
07/01/2017	Fort Garry Industries...	FGI- steering shock-wheel bearing...	180.42	19,468.79
07/01/2017	Fort Garry Industries...	FGI- ac compressor-brake shoes-k...	1,973.19	21,441.98
07/18/2017	Warner Industries S...	Warner-air switch	124.04	21,566.02
07/21/2017	Fort Garry Industries...	FGI-mirrors	17.96	21,583.98
07/25/2017	Warner Industries S...	Warner-block heater kit	86.81	21,670.79
07/25/2017	Sterling Truck & Trail...	#14A - AC hose	137.96	21,808.75
07/26/2017	Brake & Drive	B&D-electrical box	25.79	21,834.54
07/28/2017	Purolator	Purolator-Sterling Truck	47.74	21,882.28
07/28/2017	Rosenau Transport ...	Rosenau-SS Rig and Vac	228.07	22,110.35
07/31/2017	Nodge Manufacturing	Nodge- leceling ram-hydraulic hose	101.84	22,212.19
07/31/2017	Pioneer Co-op	poly lt-Co-op	9.50	22,221.69
07/31/2017	Pioneer Co-op	tape-Co-op	29.55	22,251.24
07/31/2017	Pioneer Co-op	poly med-Co-op	17.96	22,269.20
08/01/2017	Brake & Drive	B&D-mud flap-fog lights	264.57	22,533.77
08/01/2017	Brake & Drive	B&D-back up alarm-hood latch	69.60	22,603.37
08/01/2017	Napa / UAP Inc.	Napa-primer	-132.89	22,470.48
08/01/2017	Master Card	Can Tire-paint-MC	237.70	22,708.18
08/01/2017	Master Card	Namco- drop box nut/washer-MC	47.00	22,755.18
08/01/2017	Master Card	Diamond-metal-MC	37.31	22,792.49
08/01/2017	Master Card	Diversified-turn buckles-MC	579.60	23,372.09
08/01/2017	Master Card	Sterling-ac hose-MC	199.60	23,571.69
08/01/2017	Master Card	Namco-drop box-MC (repair not ca...	2,939.00	26,510.69
08/02/2017	Greyhound	Greyhound-Namco ship gear box	97.44	26,608.13
08/04/2017	Fort Garry Industries...	FGI-mud flaps	12.59	26,620.72
08/08/2017	Fort Garry Industries...	FGI-ac clutch	100.70	26,721.42
08/09/2017	Warner Industries S...	Warner-oil breather	8.74	26,730.16
08/09/2017	Napa / UAP Inc.	Napa-hydraulic hoses-fittings	566.25	27,296.41
08/09/2017	Tanya Haukeness	decals	605.00	27,901.41
08/09/2017	Nodge Manufacturing	Nodge- oil press-fittings	12.74	27,914.15
08/10/2017	CTS Kenworth	CTS-ac dyer	52.13	27,966.28

Southern Pressure Testers Ltd.
Transaction Detail By Account
January 2017 through December 2022

Date	Name	Memo	Amount	Balance
08/11/2017	Warner Industries S...	Warner-ac clutch-switch	157.47	28,123.75
08/14/2017	Raven Oilfield Supply	Raven-swivel-fitting-hose-tank patc...	355.38	28,479.13
08/14/2017	B & L Tire Services	B&L-2 tires-change over (replacem...	2,064.06	30,543.19
08/15/2017	Brake & Drive	B&D-wire	37.00	30,580.19
08/15/2017	Warner Industries S...	Warner-oil pump (repair not capital...	1,801.82	32,382.01
08/15/2017	SS Rig & Vac - AB	SS Rig- repair rod hook	723.44	33,105.45
08/15/2017	SS Rig & Vac - AB	SS Rig- inspect-repair-recertify bloc...	1,781.25	34,886.70
08/15/2017	SS Rig & Vac - AB	SS Rig- recertify clevis	465.07	35,351.77
08/15/2017	SS Rig & Vac - AB	SS Rig- repair climbing device	670.54	36,022.31
08/15/2017	Napa / UAP Inc.	Napa-elec switch	39.92	36,062.23
08/15/2017	Napa / UAP Inc.	Napa-fender wells paint	25.56	36,087.79
08/16/2017	Apex Distribution Inc.	belly valves-hose-fitting-Apex	753.00	36,840.79
08/17/2017	CTS Kenworth	CTS-clutch rods	314.48	37,155.27
08/20/2017	American Express	aluminum polish-Dunlop-Amex	87.87	37,243.14
08/31/2017	Master Card	Applied-seals-MC	163.22	37,406.36
08/31/2017	Master Card	Diamond-door panel-MC	29.23	37,435.59
08/31/2017	Master Card	Sterling-power steering rebuild kit-...	-171.48	37,264.11
08/31/2017	Master Card	Diamond-leveling ram plates-MC	155.51	37,419.62
08/31/2017	Master Card	Diamond-front fender-MC	13.95	37,433.57
08/31/2017	Master Card	Diamond-fender wells	202.54	37,636.11
08/31/2017	Pioneer Co-op	Co-op-poly-iron	14.96	37,651.07
09/01/2017	Sterling Truck & Trai...	Sterling-hose	-53.28	37,597.79
09/01/2017	Greyhound	Greyhound-SS&Rig	40.07	37,637.86
09/06/2017	Raven Oilfield Supply	Raven-2 pipe wrenches-sledge ham...	825.40	38,463.26
09/06/2017	Sterling Truck & Trai...	Sterling-temp sensor-wiring	89.03	38,552.29
09/07/2017	Raven Oilfield Supply	Raven-polish rod clamp-gauges-wr...	1,723.68	40,275.97
09/08/2017	Sterling Truck & Trai...	Sterling-thermatie fan switch	187.78	40,463.75
09/08/2017	Purolator	Purolator-Regina Volvo-thermal fa...	27.82	40,491.57
09/08/2017	Raven Oilfield Supply	Raven-nipple-coupling-slings-allen ...	483.74	40,975.31
09/11/2017	Trevor Gedny Welding	Gedney-build wheel wrench and pl...	604.69	41,580.00
09/15/2017	Purolator	Purolator-Regina Volvo-temp sensor	27.44	41,607.44
09/18/2017	Fort Garry Industries...	FGL-ratchet boomers	296.64	41,904.08
09/25/2017	Nitro	Nitro-packing-gaskets	276.96	42,181.04
09/30/2017	Pioneer Co-op	Co-op-cable clamps	8.61	42,189.65
09/30/2017	Pioneer Co-op	Co-op hand rail paint	32.34	42,221.99
09/30/2017	Master Card	#14A - Diamond steel-flow grate-MC	78.33	42,300.32
09/30/2017	Master Card	#14A - Diversified-screw pump lift ...	249.07	42,549.39
10/03/2017	Warner Industries S...	Warner-alternator	276.25	42,825.64
10/04/2017	Napa / UAP Inc.	Napa-alternator belts	50.26	42,875.90
10/25/2017	Great West Auto Ele...	GWA-v belt	32.54	42,908.44
10/27/2017	Kane Instrumentatio...	Kane-rebuild and calibrate weight i	890.25	43,798.69
11/01/2017	Fred's Trophies	tags	36.98	43,835.67
11/01/2017	Greyhound	Greyhound-Kane	63.76	43,899.43
11/02/2017	Warner Industries S...	Warner-temp solenoid	55.67	43,955.10
11/06/2017	Cervus Equipment P...	Cervus-clutch (repair not capital - ...	1,340.57	45,295.67
11/08/2017	Raven Oilfield Supply	Raven-nipples-elbow-bushings	133.53	45,429.20
11/09/2017	Kane Instrumentatio...	Kane-rent weight indicator	250.00	45,679.20
11/14/2017	Brake & Drive	B&D-wheel axle seals	124.01	45,803.21
11/14/2017	Fabro Enterprises Ltd.	Fabro-reface flywheel	142.71	45,945.92
11/15/2017	Greyhound	Greyhound-Kane	73.93	46,019.85
11/20/2017	American Express	Amex-Dunlop-shifter boot	60.76	46,080.61
11/27/2017	Hopf Mechanical & ...	Hopf-hydraulic parts (repair not ca...	1,038.72	47,119.33
12/01/2017	Warner Industries S...	Warner-alternator idler-tensioner-b...	317.75	47,437.08
12/05/2017	Raven Oilfield Supply	Raven-nipples-elbow-swivel-adapt...	75.74	47,512.82
12/06/2017	Rosenau Transport ...	Rosenau-Shaw-drill line	195.19	47,708.01
12/06/2017	Nodge Manufacturing	Nodge-hydraulic fittings	104.68	47,812.69
12/12/2017	Warner Industries S...	Warner-relay	15.29	47,827.98
12/13/2017	Brake & Drive	B&D-thermatic fan sensor	138.70	47,966.68
12/22/2017	Brake & Drive	B&D-thermal switch	143.20	48,109.88
12/22/2017	Warner Industries S...	Warner-air hose	56.96	48,166.84
12/31/2017	Master Card	MC-Shaw's-# 14A drill line	870.00	49,036.84
12/31/2017	Master Card	MC-Diamond Steel-#14A flat iron	21.56	49,058.40
01/12/2018	Brake & Drive	B&D-thermal fan switch	139.32	49,197.72
01/12/2018	Napa / UAP Inc.	Napa-junction box	16.88	49,214.60
01/15/2018	Greyhound	Greyhound-HOPF	54.62	49,269.22
01/16/2018	Brake & Drive	B&D-thermal air switch	-129.37	49,139.85
03/05/2018	B & L Tire Services	B&L-2 tires	1,499.54	50,639.39
03/15/2018	Brake & Drive	B&D-wheel check	36.23	50,675.62

Southern Pressure Testers Ltd.
Transaction Detail By Account
January 2017 through December 2022

Date	Name	Memo	Amount	Balance
03/26/2018	Napa / UAP Inc.	Napa-coscket-ratchet	63.09	50,738.71
03/26/2018	Napa / UAP Inc.	Napa-hammer	25.36	50,764.07
03/31/2018	Master Card	Diamond steel- #14A tool box hinges	24.73	50,788.80
04/03/2018	Raven Oilfield Supply	Raven-tank patch	136.00	50,924.80
04/09/2018	Nodge Manufacturing	Nodge-hydraulic fittings	45.12	50,969.92
04/10/2018	TS&M Supply	TS&M-rod table	1,982.87	52,952.79
04/12/2018	TS&M Supply	TS&M-rod table	-565.95	52,386.84
04/27/2018	Napa / UAP Inc.	Napa-adjustable wrench-ratchet-br...	218.77	52,605.61
04/30/2018	Pioneer Co-op	Co-op-rcht strap	21.13	52,626.74
04/30/2018	Master Card	Diamond Steel- #14A steel for bop	52.55	52,679.29
04/30/2018	Master Card	Prairie Indust. - #14A wrench-sled...	59.48	52,738.77
05/02/2018	Napa / UAP Inc.	Napa-fan belt	55.79	52,794.56
05/02/2018	Raven Oilfield Supply	Raven-hose whip check	25.33	52,819.89
05/04/2018	TS&M Supply	TS&M-bop assembly	2,518.89	55,338.78
07/01/2018	Greyhound	Greyhound-Namco-box seals	37.75	55,376.53
10/01/2018	Apex Distribution Inc.	Apex-hose-fitting-adapter	45.11	55,421.64
10/03/2018	Great West Auto Ele...	GWA-cab heater	407.18	55,828.82
10/09/2018	Warner Industries S...	Warner-idler pulley-fan belts	369.87	56,198.69
10/11/2018	Raven Oilfield Supply	Raven-hose-fitting-fuel line	78.62	56,277.31
10/30/2018	Master Card	Sterling - #14A fan belts & idler pul...	479.58	56,756.89
10/31/2018	Pioneer Co-op	#14A plastic elbow	1.75	56,758.64
11/01/2018	Greyhound	freight from Dunlop	48.57	56,807.21
11/22/2018	Raven Oilfield Supply	insulation	20.56	56,827.77
12/20/2018	Raven Oilfield Supply	3" collar	17.21	56,844.98
12/28/2018	B & L Tire Services	change over	46.51	56,891.49
01/01/2019	Raven Oilfield Supply	foil-knife-sling	212.23	57,103.72
01/02/2019	Warner Industries S...	bearing-yoke	90.16	57,193.88
01/02/2019	Warner Industries S...	yoke	168.91	57,362.79
01/09/2019	Nodge Manufacturing	hydraulic cap	52.84	57,415.63
01/09/2019	Rosenau Transport ...	SS rig-freight-deliver crown saver	120.49	57,536.12
01/10/2019	Raven Oilfield Supply	threded petrotape	76.30	57,612.42
01/10/2019	Warner Industries S...	tranny bearing-seal	313.90	57,926.32
01/11/2019	Fort Garry Industries...	compressor (r&m - dhr)	1,611.09	59,537.41
01/14/2019	Warner Industries S...	speed sensor	35.55	59,572.96
01/15/2019	Fountain Tire	8 tires (replacement - dhr)	3,483.21	63,056.17
01/17/2019	B & L Tire Services	1 tire	748.71	63,804.88
01/17/2019	Raven Oilfield Supply	polish rod	111.08	63,915.96
01/22/2019	Warner Industries S...	filter	139.35	64,055.31
02/01/2019	SS Rig & Vac - AB	crown saver (replacement - dhr)	1,929.05	65,984.36
02/13/2019	Warner Industries S...	hub-spline coupling	195.11	66,179.47
02/15/2019	Warner Industries S...	Hub-sline coupling	-131.86	66,047.61
02/25/2019	CTS Kenworth	starter	662.10	66,709.71
02/25/2019	Trappers Auto Tech	cold crankier battery	632.71	67,342.42
02/26/2019	CTS Kenworth	starter credit	-209.31	67,133.11
03/13/2019	Raven Oilfield Supply	nipple-rags-knife	123.67	67,256.78
03/18/2019	Great West Auto Ele...	grease gun	73.37	67,330.15
03/20/2019	Warner Industries S...	tie rod end	158.51	67,488.66
03/25/2019	Fountain Tire	1 tire	244.90	67,733.56
03/31/2019	Pioneer Co-op	hose menders-clamps	17.13	67,750.69
04/06/2019	Nodge Manufacturing	fittings for crown saver	132.86	67,883.55
04/08/2019	Brake & Drive	air hose	91.24	67,974.79
04/10/2019	MacMor Industries	fall arrest (replacement - dhr)	1,480.00	69,454.79
04/11/2019	Farmland Supply - AB	fittings	46.20	69,500.99
04/11/2019	Nodge Manufacturing	valves	30.16	69,531.15
04/11/2019	Nodge Manufacturing	fittings	29.50	69,560.65
04/11/2019	Nodge Manufacturing	hydraulic fittings	243.86	69,804.51
04/12/2019	Cartel Energy Servic...	hotshot cables (freight - dhr)	1,191.93	70,996.44
04/12/2019	Napa / UAP Inc.	u bolts	22.37	71,018.81
04/12/2019	Nodge Manufacturing	fittings	289.17	71,307.98
04/15/2019	Warner Industries S...	oil filter	29.17	71,337.15
04/15/2019	TS&M Supply	fittings	33.18	71,370.33
04/16/2019	Warner Industries S...	tie rod end	67.92	71,438.25
04/17/2019	Raven Oilfield Supply	clevis	230.19	71,668.44
04/22/2019	Apex Distribution Inc.	tee-bushing-nipple-coup;imgs-hos...	296.98	71,965.42
04/30/2019	Pioneer Co-op	rope	15.07	71,980.49
04/30/2019	Pioneer Co-op	wood-screws	233.25	72,213.74
04/30/2019	Pioneer Co-op	nuts and bolts	8.25	72,221.99
04/30/2019	Pioneer Co-op	paint	8.70	72,230.69

Southern Pressure Testers Ltd.
Transaction Detail By Account
 January 2017 through December 2022

Date	Name	Memo	Amount	Balance
04/30/2019	Pioneer Co-op	hacksaw	31.70	72,262.39
04/30/2019	Master Card	Total Oilfield Rentals	713.57	72,975.96
04/30/2019	Master Card	Diamond Steel-crown saver iron	24.52	73,000.48
04/30/2019	Master Card	Shaws- load lines	481.40	73,481.88
04/30/2019	Master Card	hack saw and blades	38.17	73,520.05
04/30/2019	Master Card	RV Auto parts	23.21	73,543.26
04/30/2019	Master Card	Pattison Ag-hydraulic hose	572.50	74,115.76
04/30/2019	Master Card	Applied-hydraulic hose	300.26	74,416.02
05/31/2019	Fauser Energy	#14A wash	117.69	74,533.71
06/01/2019	Raven Oilfield Supply	rod wiper	164.80	74,698.51
07/30/2019	Warner Industries S...	speed sensor	36.24	74,734.75
08/09/2019	Warner Industries S...	injector (repair - dhr)	2,001.40	76,736.15
08/16/2019	Automotive Unlimite...	check cylinder head for crakes-cle...	1,113.84	77,849.99
08/23/2019	Warner Industries S...	injector	-648.74	77,201.25
10/31/2019	Master Card	Low cost towing	400.00	77,601.25
Total #14A R&M			77,601.25	77,601.25
Total Repair & Maintenance Exp - 5770			77,601.25	77,601.25
TOTAL			77,601.25	77,601.25

2017-2019
 Total Repairs

Put into service Aug. 22/17
 Parked Aug. 9/19